



ILE No.:TIAN-QW-070002-03

DATE:2014/05/30

REV: A/1

## 深圳市天澜电子科技有限公司

### 手写类触摸屏规格承认书

品 名: 类比式触摸屏

产品型号: TIAN-070002-03

产品编号: \_\_\_\_\_

客户名称 \_\_\_\_\_

客户型号 \_\_\_\_\_

客户确认: \_\_\_\_\_

日 期: \_\_\_\_\_

工程	品质	制订
陈文勇	Amorll.邓	简猜

深圳市南山区南海大道百富大厦A座24层

TEL:+86-0755-26487325、26487327、26487030

FAX:+86-0755-26487326

<http://www.topland.com.hk>

E-mail://[info@topland.com.hk](mailto:info@topland.com.hk)

# TABLE OF CONTENTS

## 目 录

01. Table of Contents[目录].....	02
02. Circumscription [范围].....	03
03. Features [特性] .....	03
04. General Specification [规格总则] .....	03
05. Environmental Characteristics [环境特性].....	03
06. Optical Characteristics [光学特性] .....	03
07. Electrical Characteristics [电子特性].....	03
08. Mechanical Characteristics [机械特性]....	04
09. Reliability [信赖性].....	04
10. Durability [耐久性].....	04
11. Appearance Inspection [外观检查].....	05、06

**02. Circumscription** The specification is for Four-Wire analog resistive touch panel.

[范围]

[此规格适用于四线-模拟电阻式触控屏幕]

**03. Features**

[特性]

Item [项目]		Specifications [规格]
(1)	Product Structure [产品结构]	F/G [ITO胶片/ITO玻璃]
(2)	ITO Glass [ITO 玻璃]	TP 1.1mm
(3)	ITO Film [ITO 胶片]	亮面防牛防刮伤
(4)	Input Mode [操作模式]	Stylus or Finger [笔触或手触]
(5)	Connector [连接方式]	FPC

**04. General Specification**

[规格总则]

Item [项目]		Specifications [规格]
(1)	Frame Size [外形尺寸]	164.8×99.6×1.4±0.1mm
(2)	Tail Length [出线长度]	79.5±0.5mm FPC型号: RXA-8110C

**05.Environmental Characteristis**

[环境特性]

Item [项目]		Specifications [规格]	
(1)	Operation [操作]	-10°C ~ +60°C	20%RH ~ 85%RH
(2)	Storage [储存]	-20°C ~ +70°C	10%RH ~ 90%RH

Note: The environment is under normal atmosphere pressure.

[注:于正常的1 大气压下]

**06. Optical Characteristics**

[光学特性]

Item [项目]		Specifications [规格]
(1)	Transparency [透光率]	≥78%-550nm

**07. Electrical Characteristics**

[电子特性]

Item [项目]		Specifications [规格]
(1)	Terminal resistance [回路电阻]	Rx-x: 200-900 Ω Ry-y: 200-900 Ω
(2)	Linearity [线性]	≤1.5%
(3)	Chattering [触点抖动时间]	≤15ms
(4)	Insulation [绝缘阻抗]	≥20MΩ/25V(DC)

### 08. Mechanical Characteristics

[机械特性]

	Item [项目]	Specification [规格]	Condition [条件]
(1)	Operating Force [操作压力]	Stylus=R0.8 [笔式=R0.8]	Range at 50g~115g
(2)	Hardness [硬度]	3H pencil, pressure 1N/45 [铅笔3H,压力1N/45° ]	≥3H

### 09. Reliability

[信赖性]

	Item [项目]	Specifications [规格]	Condition [条件]
(1)	Constant Temperature /Humidity [恒温恒湿]	60°C /90%RH, 120 hrs and normalized for 24hrs [60°C /90%RH, 120 小时, 回常温24小时后始可测试]	Satisfy (1),of Item6; (1),(2),(3)(4) of Item 7; (1) (2) of Item8 [符合6项(1)、及7项目(1)、(2)、(3)(4)及8项目(1)(2)]
(2)	Heat Test [高温测试]	70°C /120 hrs and normalized for 24 hrs [70°C 1/20 小时, 回常温 24 小时后始可测试时]	Same as above [同上]
(3)	Cold Test [低温测试]	-30°C /120 hrs and normalized for 24 hrs [-30°C /120 小时, 回常温 24 小时后可测试]	Same as above [同上]
(4)	Thermal Cycle [冷热循环]	-20°C ~70°C [60 min./cycle] *10cycles and normalized for 24hrs [-20°C ~60°C, 每循环60 分钟, 共10次循环, 回常温 24 小时后始可测试]	Same as above [同上]

### 10. Durability

[耐久性]

	Item [项目]	Specifications [规格]	Condition [条件]
(1)	Knock Test [敲击测试]	1,000,000 times [R8,hardness 60°,150gf 约3次/sec]	Satisfy (1),of Item 6;(1), (3) (4) of Item 7; (2) of item 7 satisfies X≤3.0%, Y≤3.0% [符合6项(1)及7目(1)(3)、(4) ; 7项(2)符合 X≤3.0%,Y≤3.0%]
(2)	Impact [撞击]	15ΦDIA. Steel Ball/ Hight=30cm [15Φ/ 不锈钢球 高=30cm]	1 time, no damage [Impact at center area] [中央区域撞击1次,不能破损]

11. Appearance Inspection  
[外观检查标准]

(1) The flaws and impurities are allowed outside viewing area except for those affecting electrical functions.  
[(1) 只要不影响电器功能性, 可视区外之外观瑕疵是可以被允许的]

(2) The inspection was performed with one 20W fluorescent lamp lighting from back or side. The panel was placed 30cm away from eyes. (Figure 11-1).

[(2) 检测始用之灯光为一盏20W 白炽灯光, 并于面板后侧或上侧照射, 检测时须放置在离眼睛30cm 处(Figure11-1)]

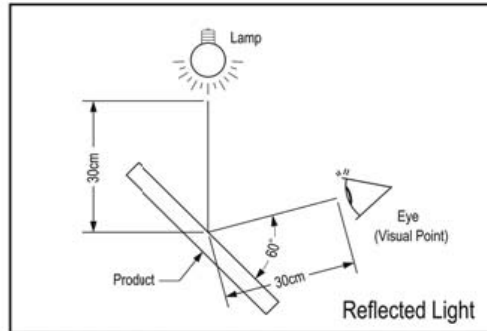

Figure 11-1

(3) Glass Flaw [玻璃瑕疵]

Item [项目]	Picture [图示]	Specification [规格]
Corner Flaw [角瑕疵]		$X \leq 3\text{mm}$ $Y \leq 1.5\text{mm}$ $Z \leq GT$ 且不影响产品功能
Edge Flaw [边缘瑕疵]		$X \leq 4\text{mm}$ $Y \leq 1.5\text{mm}$ $Z \leq GT$ 且不影响产品功能
Progressive Flaw [裂纹瑕疵]		Not allowed [不允许]

Note: GT=Glass thickness

(4) Please refer to Appendix I : Appearance Specification.

[(4)外观规格请详见(附注1)]

Item [项目]	Specification [规格]	
Appearance description [外观说明]	应用区域: 可视区 * 所有的外观不良只要是在可视区以外对产品功能不造成影响均不考虑在内 * 所有可以使用软布用酒精擦拭得掉的污染物均不考虑在内	
Particle [颗粒异物]	(1) $D < 0.20$ 可忽略 (2) $0.20 \leq D \leq 0.25$ and total $\leq 2 \rightarrow$ OK (3) $D > 0.30 \rightarrow$ NG	
Linear Object [线状异物]	(1) $W < 0.03$ 可忽略 (2) $0.03 \leq W \leq 0.05$ and $L \leq 3.0$ , total $\leq 3 \rightarrow$ OK (3) $W > 0.05$ or $L > 3.0 \rightarrow$ NG Remark: the particle will be ignored when it is cleanable.	
Scratch [刮痕]	同线状异物	
QC抽查 抽样计划/质量允许水平	MIL-STD-105D水平 II 抽样 AQL-Cr (严重缺点) 0.00% ---- 安全性缺陷 AQL-Ma (主要缺点) 0.65% ---- 功能异常缺陷 AQL-Ma (次要缺点) 1.5% ---- 刮伤与异物及外观缺陷	
Newton Ring/Rain-bow [牛顿环/干涉纹] (此项仅限于使用亮面胶片, 如使用防牛顿环胶片不需检查此项)		
Item [项目]	Standard [标准]	Picture [图示]
Rule [规则]	(1) 当牛顿环 $> 10\text{mm}$ 时, $\rightarrow$ NG (2) 当牛顿环 $\leq 10\text{mm}$ 时, 且不影响文字及直线失真 $\rightarrow$ OK	使用防牛顿环ITO胶片不检此项 
Abnormity [不规则]	(1) 牛顿环不论大小, 当亮灯后造成文字及直线失真 $\rightarrow$ NG (2) 当牛顿环 $\leq 8\text{mm}$ 时, 且亮灯后不影响文字及直线失真 $\rightarrow$ OK	使用防牛顿环ITO胶片不检此项 
Film drum [膜鼓]	(1) FILM膜局部或全部鼓起 $> 0.4\text{mm} \rightarrow$ NG (2) FILM膜局部或全部鼓起 $\leq 0.35\text{mm} \rightarrow$ OK	
Page: 06/06		

REV.	DESCRIPTION	DATE

正面图

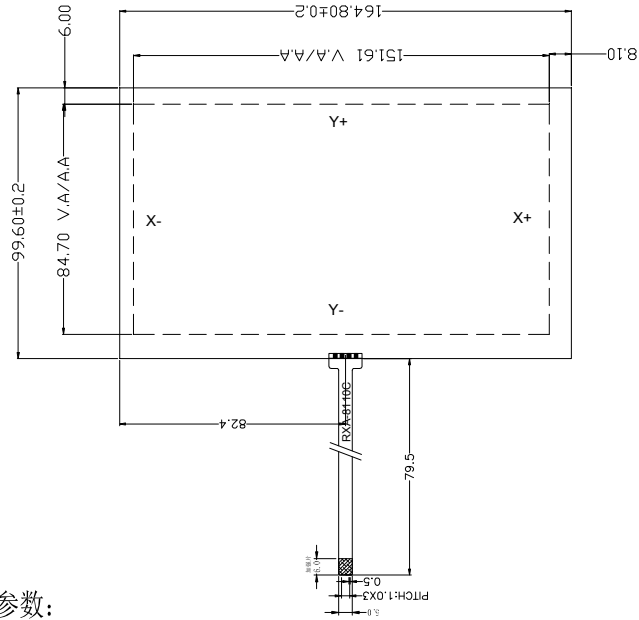

侧面图

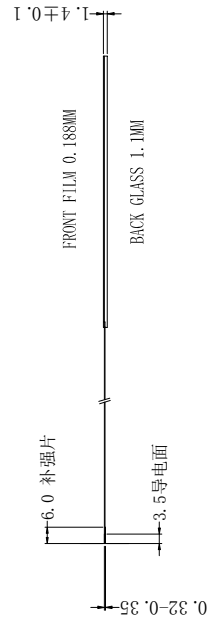

背面图

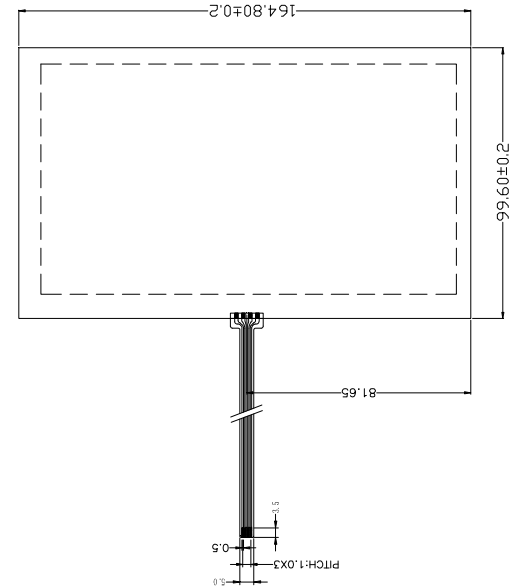

技术参数:

1. 结构: film+glass+tail  
 film: 亮面防牛 (0.188mm)  
 glass: 500 Ω/□ 普通1.1mm  
 tail: FPC (pitch1.0)  
 产品总厚度: 触摸屏 MAX 1.4±0.1mm
2. 电路等级: DC5V 1mA
3. 绝缘阻抗: ≥20M Ω (25V DC)
4. 线性: ≤1.5%
5. 透光率: ≥78%
6. 操作压力: 50-120g
7. 使用寿命: ≥1,000,000次
8. 笔划寿命: ≥100,000次:
9. 工作环境: -10℃~+60℃,
10. 储存环境: -20℃~+70℃,
11. X: 200-900 Ω Y: 200-900 Ω.
12. 未注尺寸公差按±0.50

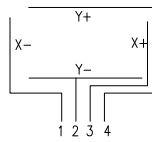

逻辑图

PIN	OUT
1	X-
2	Y-
3	X+
4	Y+

SCALE: 1 : 1 NOT TO SCALE		TOPLAND ELECTRONICS (H.K.) CO., LIMITED	
PAGE: 1 OF 1			
GENERAL TOL. 0.50mm	UNITS MM		
APPROVALS	DATE		
APP: MYchan	2014/03/10	MODEL NUMBER :	
CHK: Amor11	2014/03/10	TIAN-070002-03	
DWN: Amor11	2014/03/10		
		Product NO : RX-SJ-140310-01A	DATE: 2014/03/10